

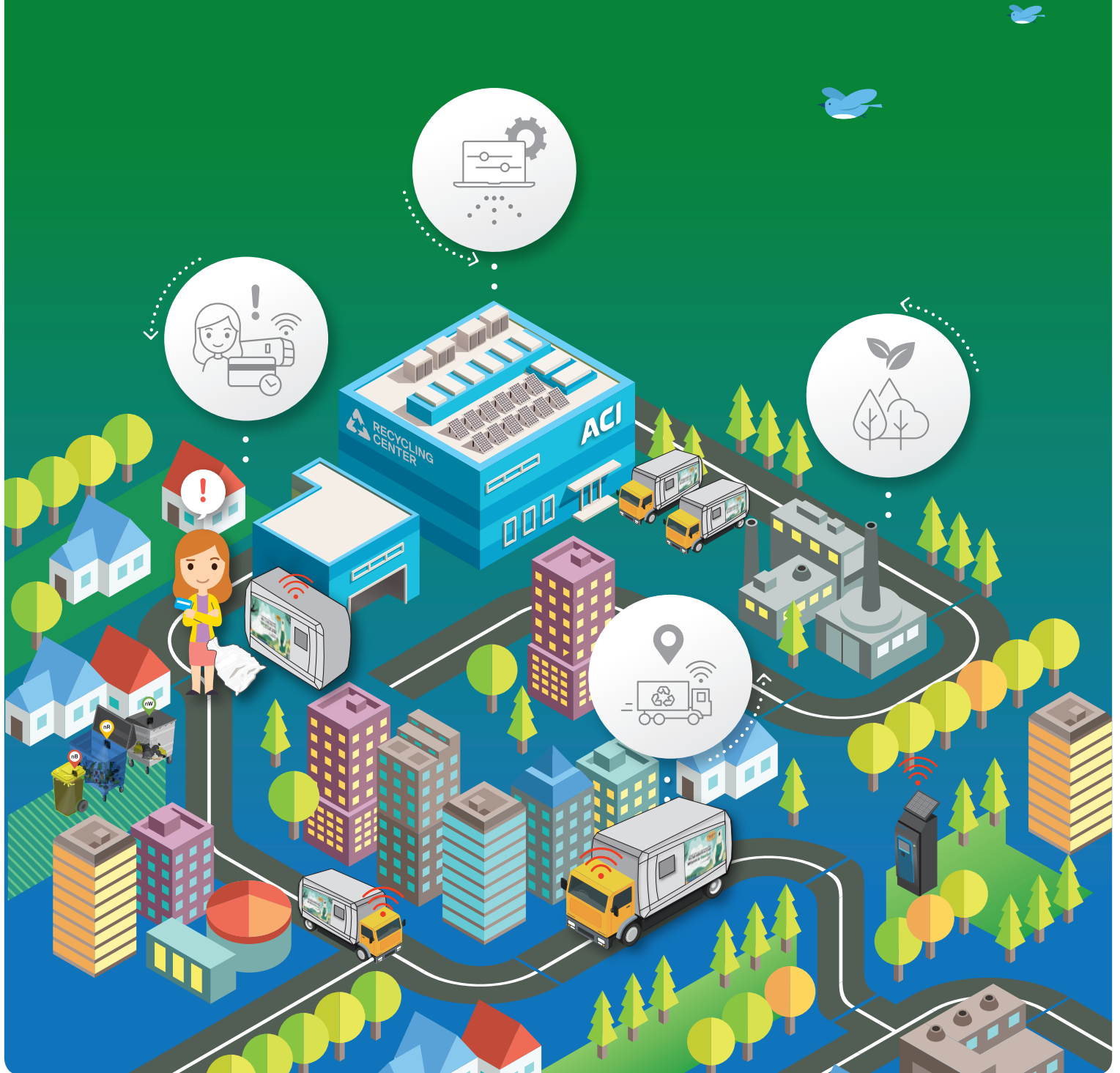

SMART Waste Collection System

# NatureStore



# Hi! My name is Begcomsee, the Polar Bear. Welcome to Nature Store!

In **Nature Store**, we sell Clean Air,  
Blue Sky, Brilliant Sunshine, and Green Nature.  
Buy the Clean and Safe Environment.

From my experience I have learned that we need to save the Earth and the Arctic by recycling the waste.  
I opened up Nature Store where we can separate and treat the waste for recycling.  
In Nature Store, I manage your wastes in smart ways.

Welcome to Nature Store and meet Mr. Begcomsee, the Polar Bear.

By visiting Nature Store, we can make the clean and safe environment  
where the human and other animals live together.  
So I can go back to my home at the Arctic.



## Contents

- 02 Story of Nature Store
- 04 IoT Compacting Containers, iTainer
- 10 Machine for Food Waste, iDry-B
- 12 Solar Powered Automatic Compacting Bin, iSolarbin
- 14 Bin Level Sensor, iNetbin
- 15 Underground Waste Collection, iUnderground
- 16 Waste Collection Management System, iEcopro C

ACI SMART Waste Collection System

# NatureStore

No need to make the plastic bags to collect the waste

No need to relimit the waste discharging hours

No need to have the waiting until the waste bag is filled

Nature Store will open the new era of nature friendly waste collection



Nature Store iTainer is the most advanced automatic waste compacting container equipped with IoT/ICT technology. The computer system will control the operation and the operator will solve any problem remotely through the internet connection.

# iTainer



AS Service Engineer



Safety & Maintenance

## / IoT Platform Waste Compacting Container /



Error



Alarm on System



Remote Maintenance Support



Dispatch Engineer



Non Stop Operation

### • Features & Advantages



- Less collection workers and trucks by 80%
- No new plastic bag for waste
- Less traffic burden and CO<sub>2</sub> emission



- Collecting fully loaded containers only
- Compacting fluffy waste bags upto 80%
- Easy to hookup type container



- No waste dispersion, No odor, No vermin
- No waste bag breakup by animals

### The Most Efficient Waste Collection System ▶



Waste Load Monitoring by Internet



Container Pickup at Over 80% Load



Waste Collection Truck Monitoring

### Easy Waste Discharging From Dumping to Payment ▶



Payment System (Credit Card, RF Card)



Weighing Waste



Compacting for Volume Reduction



Odor Generation controlled by Ozone

# NatureStore

| for Municipal Solid Waste |

## iTainer-W

Nature Store iTainer-W weighs municipal solid waste and charges cost. by Credit Card and RF Card.

- 1 Fire Detector
- 2 Campaign AD
- 3 Smart Control
- 4 Weighing Scale
- 5 Odor Control
- 6 Internet/GPS
- 7 Dumping Gate
- 8 Compacting Unit
- 9 Shutter Open Sensor
- 10 Payment System

**Applications** [ Residential Area / Market / Apartment Complex / Festival Area and big Complex ]

### Process

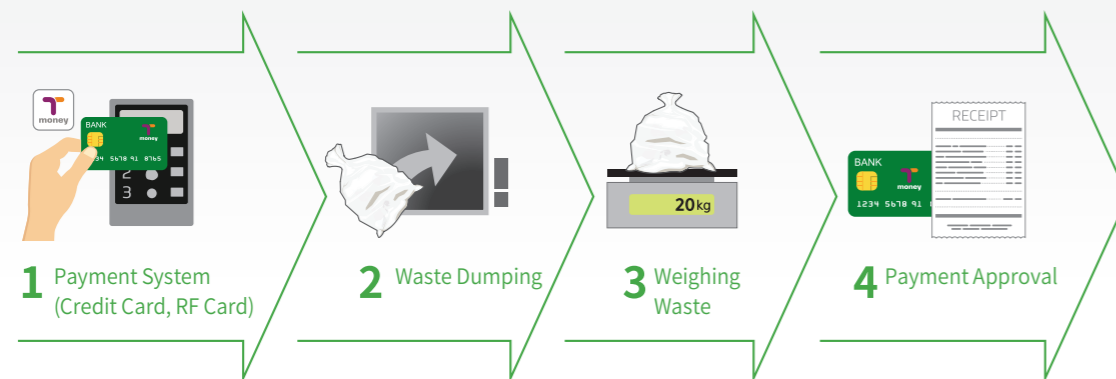

### Benefits

- Fuel Saving
- Reduced CO2
- Clean City
- Easy Payment



### Technical Spec

Division	iTainer-W10	iTainer-W8	iTainer-W7N
Capacity	10CBM / 5ton	8CBM / 4ton	7CBM / 3.5ton
Pressing Force	200kN		
Weighing Scale	0.05 ~ 60kg		
Power Consumption	5.5kW / Φ3 x 380V x 60Hz		
Dimensions	W2,200 x L5,150 x H2,255	W2,200 x L4,500 x H2,215	W1,700 x L4,500 x H2,215

\* The specifications can be modified for the quality improvement.

Division	iTainer-WS10	iTainer-WS7	iTainer-WS5
Capacity	10CBM / 5ton	7CBM / 3.5ton	5CBM / 2.5ton
Weighing Scale	0.05 ~ 30kg		
Power Consumption	4.0/5.5kW / Φ3 x 380V x 60Hz		
Dimensions	W1,700 x L5,000 x H2,210	W1,700 x L4,000 x H2,210	W1,700 x L2,750 x H2,210

\* The specifications can be modified for the quality improvement.

### Truck Unloading / Loading Spec

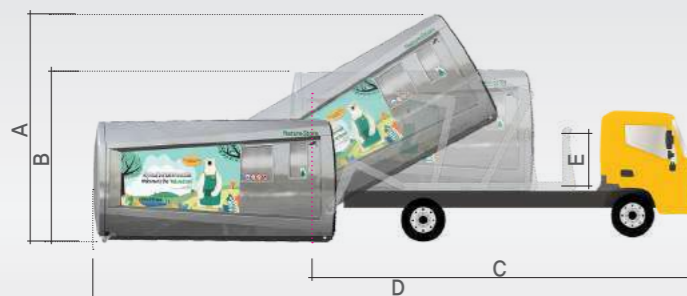

iTainer W10/8/7N with Truck and HIAB

\* Unit:mm

Division	iTainer-W10	iTainer-W8	iTainer-W7N
A	4,160	4,289	4,200
B	3,365	3,355	3,150
C	8,327	7,365	6,755
D	14,400	11,700	11,100
E	1,570	900	900

\* The specifications can be modified for the quality improvement.

# NatureStore | for Food Waste | iTainer-B

Nature Store iTainer-B weighs food waste and charges cost. Payment by Credit Card and RF Card.

## Applications

[ Residential Area / Apartment Complex / Shopping Center / Restaurant Area ]

## Process

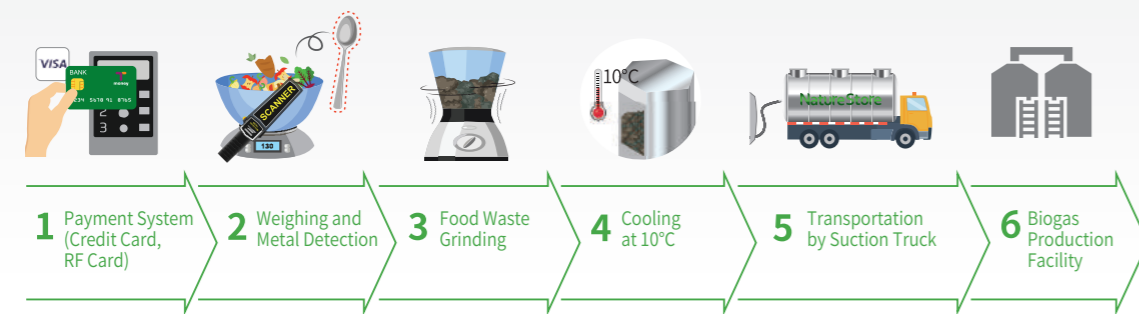

## Benefits



## Description



- 1 Cooling System
- 2 Campaign AD
- 3 Odor Control
- 4 Fire Sensor
- 5 Metal Detector
- 6 Auto Washing
- 7 Grinding/Pumping
- 8 Internet/GPS
- 9 Smart Control System
- 10 Payment System
- 11 Weighing Scale
- 12 Shutter Open Sensor

# NatureStore | for Recycle Waste | iTainer-R

Nature Store iTainer-R is to collect the recyclable waste with AI Camera. The users registered with the mobile app or at the internet site can read QR or Bar Code on iTainer. iTainer R will take the buckets of recyclable wastes at once and recognize item by item with AI camera. The system will pay the users on the value of the recyclables by the mobile payment.

## Applications

[ Residential Area / Market / Apartment Complex / Festival Area ]

## Process

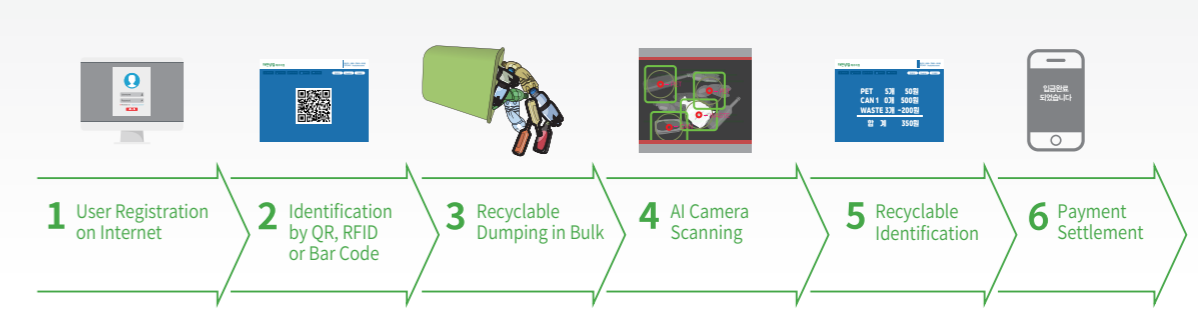

## Benefits



## Description



- 1 Campaign AD
- 2 Odor Control
- 3 Fire Sensor
- 4 AI Camera & Bucket
- 5 Smart Control & Touch Screen
- 6 Compacting Unit
- 7 Internet/GPS
- 8 QR or Bar Code
- 9 Shutter Open Sensor

# NatureStore

| Machine for Food Waste |

## iDry-B

Nature Store iDry-B is to collect and dry food waste from the restaurants and houses to save collection cost. With the weighing scale in machine, iDry B will charge the customer with Credit Card and RF Card.

### Applications [ Residential Area, Restaurant Area, Fish Market, Cafeteria ]

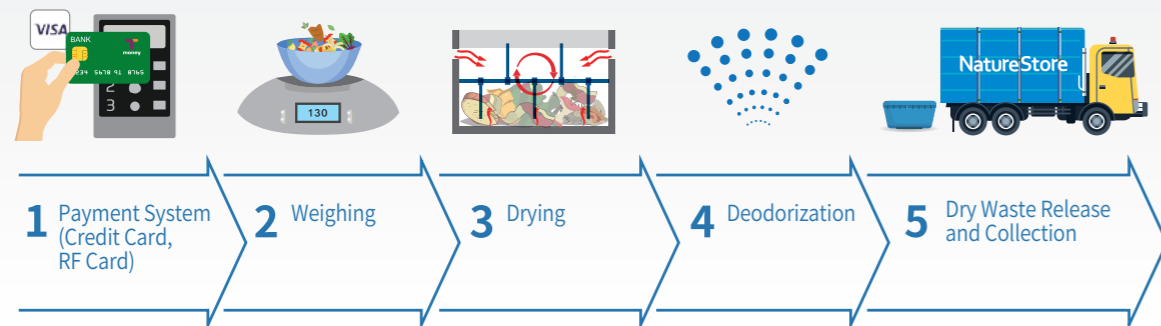

### Features & Advantages

#### Cost Saving

- Heat Dry from Fin Heater and Bio Drying from Composting
- Drying Heat recovered and recycled to save Cost
- Remaining Dried Food Waste works as moisture controller for new waste

#### High Efficiency

- Accumulative feeding for 7 days possible
- Odor control system from Platinum Catalyst
- Highly reliable structure for long lifetime

#### Convenience

- Automatic Control System with Moisture Sensor
- Dried Food Waste collected every 3-7 days

### Benefits

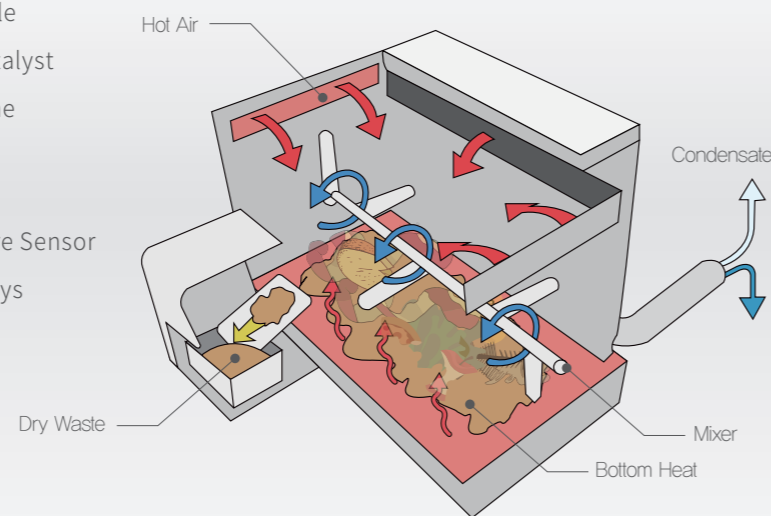

Heat and Bio Drying System Concept

### Model & Technical Spec

For Residential Area : Apartment, Villa, House, Small Restaurant



Model	iDry-B 100E	iDry-B 200E
Capacity	100kg / day	200kg / day
Electricity	380V-400V 50-60Hz	
Electrical Consumption/day	70~80kWh (may vary)	99kWh (may vary)
External Dimension	W1,950 x D1,320 x H1,520	W2,250 x D1,520 x H1,320
Internal Dimension	Ø610 x 1,000mm	Ø610 x 1,200mm
Odor Control System	Oxidizer with Platinum Catalyst	

\* The specifications can be modified for the quality improvement.

For Restaurant & Cafeteria : Cafeteria for School or Military, Restaurant Streets, Hotel, Hospital, Nursery Home, Kindergarden



Model	iDry-B 100ES	iDry-B 200ES
Capacity	100kg / day	200kg / day
Electricity	380V-400V 50-60Hz	
Electrical Consumption/day	70~80kWh (may vary)	99kWh (may vary)
External Dimension	W1,603 x D1,583 x H1,649	W1,803 x D1,583 x H1,649
Internal Dimension	Ø610 x 1,000mm	Ø610 x 1,200mm
Odor Control System	Oxidizer with Platinum Catalyst	

\* The specifications can be modified for the quality improvement.

# NatureStore

Solar Powered  
Compacting Bin

## iSolarbin

Nature Store **iSolarbin** is smart waste compacting bin with solar panel and fill level sensor for street, beach and stores. Centralized Control system will monitor the operation status and fill level through Internet by real time. iSolarbin compacts waste with vertical press system to increase the waste collection capacity. In the selfpowered equipment, we can add the smart city solutions.

### Applications

[ Park / Street / Fast Food Restaurant / Department Store / Beach / Festival Area / Campus ]

### Features & Advantages

#### Cleaner Space

- Eliminating overflow and critter access
- Adapted designs for various locations
- Advertisement applicable

#### High Efficiency

- IoT based fill level monitoring and compacting
- Self-powered by Solar Panel
- Upto 80% of collection work reduction
- Smaller work forces and truck fleet
- Reduced fuel consumption and CO<sub>2</sub> emission

#### Convenience

- Automatic vertical compaction
- Easy to relocate

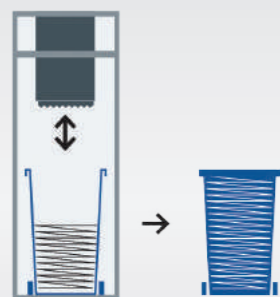

60L/120L Waste BIN

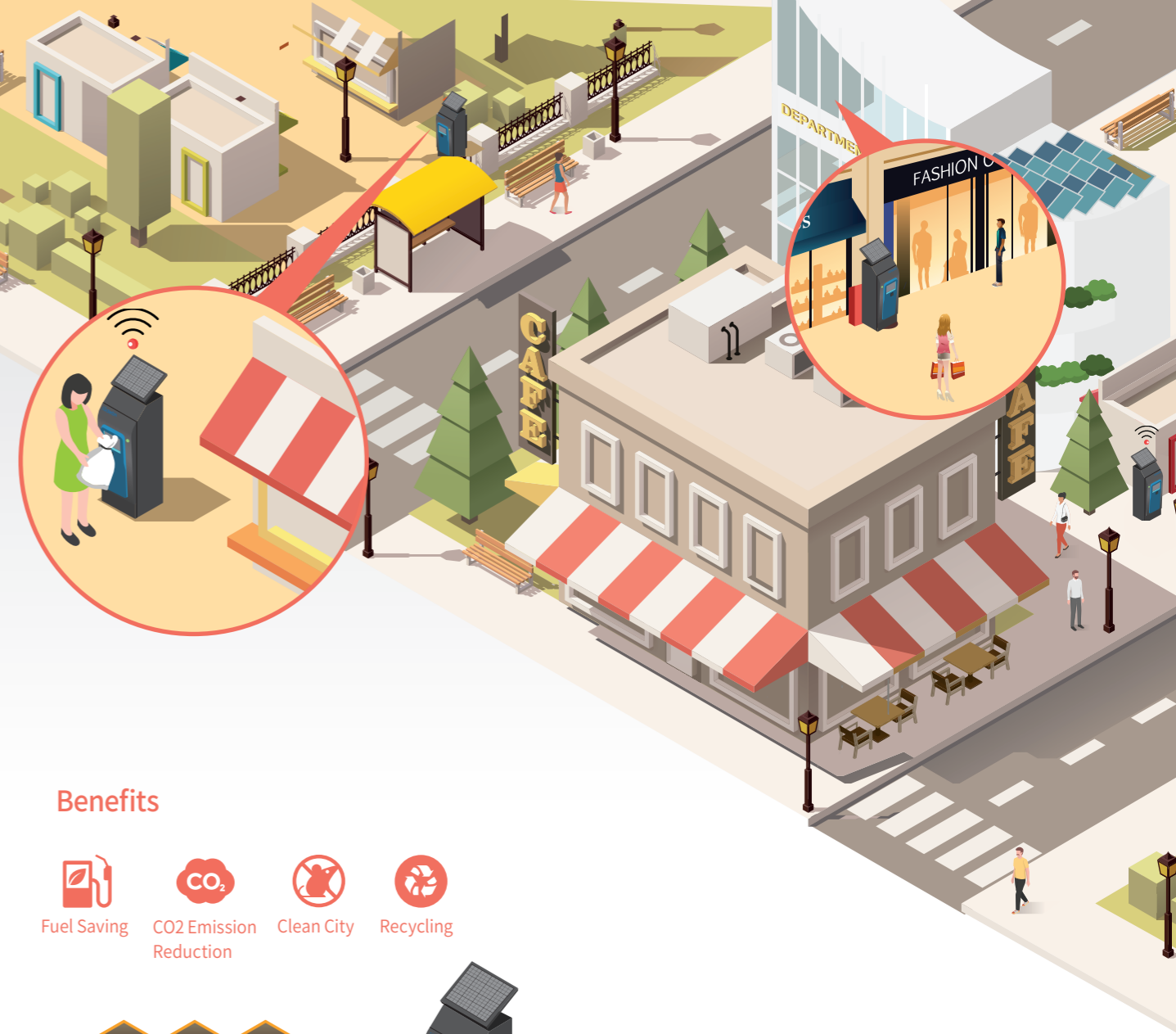

### Benefits

- Fuel Saving
- CO<sub>2</sub> Emission Reduction
- Clean City
- Recycling

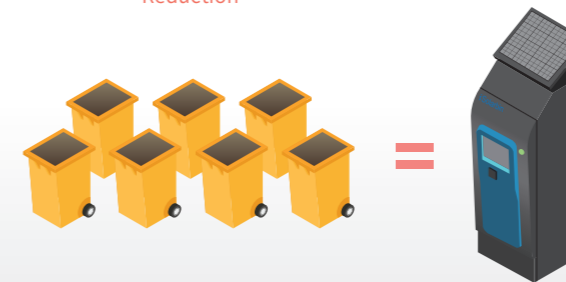

### Waste Bins by Material



# NatureStore

the SMART Fill Level  
Monitoring Sensor

## iNetbin

Nature Store **iNetbin** is a Fill Level Sensor equipped in Waste Bin. It provides timely warnings when the bin is filled at different levels. It also sends the messages to server through the internet when the bin is turned over or set on fire.

### Applications

[ Residential Area / Market / Apartment Complex / Park / Festival Area ]

### Features & Advantages

#### Cost Reduction

- Longer lifetime and less maintenance cost for waste collection truck
- Illegal waste dumping and waste bin breakage monitoring

#### Operation Efficiency

- Empty only the bins needed emptying
- Avoid ugly overflowing bins
- Increase the capacity in rapid fill areas

#### Monitor and Report

- Analyze existing collection routes against actual fill level
- Gather the data for new collection improvement schemes
- Identify trends in bin filling behaviors



### Benefits



# NatureStore

to Save the  
Collection Space

## iUnderground

Nature Store **iUnderground** is the space creator for iTainer and iNetbin when there is no space for waste collection. With iUnderground, we can keep the iTainer and waste bins under the ground. The feeding chutes are equipped with scale and payment system. Keeping the waste under the ground gives the benefit of less odor and dust.

### Applications

[ Big Residential Complex / Heavily Commercial Area / Residential and Commercial Complex / City Center ]

### Features & Advantages

#### Space Creation

- Under public park
- Under parking lot

#### High Efficiency

- Utilizing Overground
- Reduced odor generation

#### Convenience

- One stop service for all types of wastes
- Easy system from payment to waste dumping

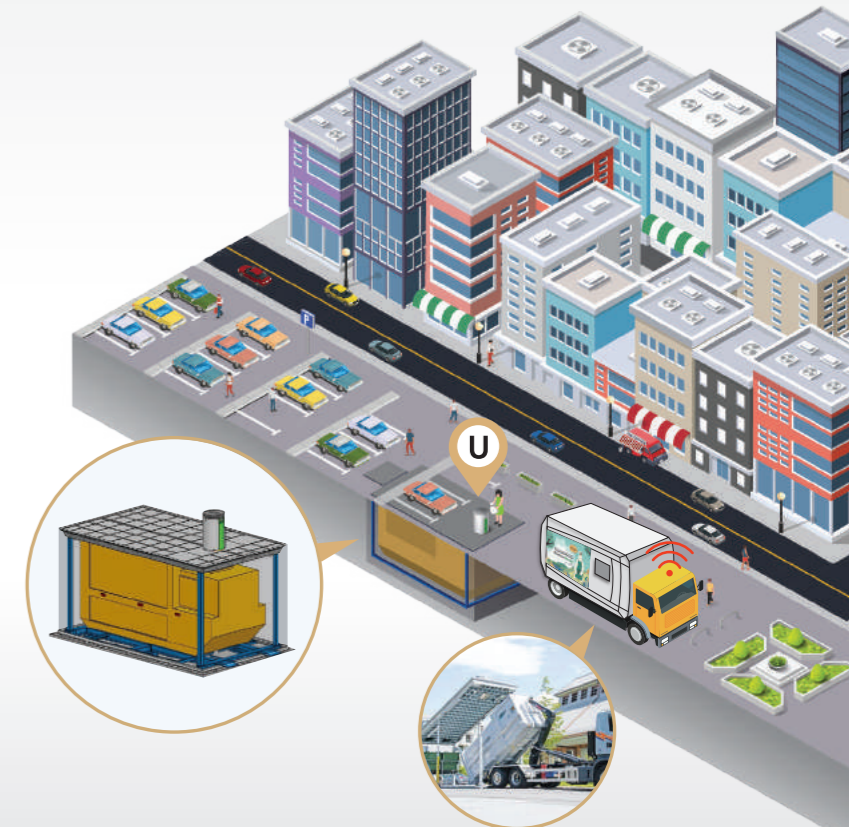

### Benefits

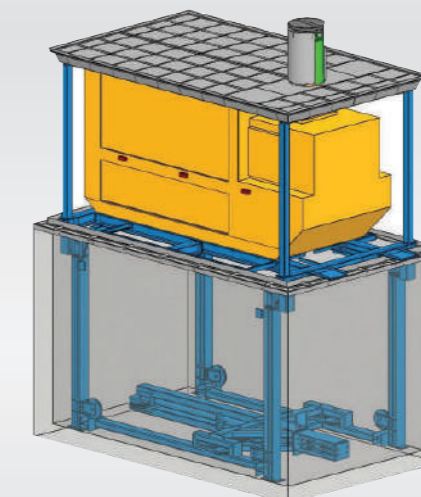



# NatureStore

Waste Collection Management System

## iEcopro C

Nature Store **iEcopro C** is the waste collection management system which controls and operates iTainer, iNetbin, iSolarbin and iDry-B connected on the internet. On the system, we can monitor the status of the machines, collect the waste related data and analyze the data for future trend forecast. The system also supports the waste collection fleet with the best practice of waste collection and maintenance staffs with the latest machine status and online service manual. iEcopro C is the best solution for the most efficient waste collection management.

### Features & Advantages

#### Total Management in One Server







- Easy to control with full overview
- Reliable database for future planning
- Most efficient solution by connecting the server to customers by APP.

#### High Efficiency

- Small waste management fleet
- Flexible and reliable management by analyzed data
- Dumping fee collection guaranteed
- Remote maintenance support system



### Benefits

-  Smart City
-  Less CO<sub>2</sub>
-  Pretty City
-  Clean City

-  Nature Store
-  iTainer
-  iSolarbin
-  iDry-B
-  iNetbin
-  iUnderground



Monitoring Waste Collection Truck Driver

-  80 – 100% filled
-  50-80% filled
-  0-50% filled



www.inaturestore.com

**NatureStore**



“Mr. Begcomsee, the Polar Bear” has the meaning that the Polar Bear is BEGging you to COMe and SEE the Arctic. “the North Pole” has been the most devastated by the Global Warming.



**Head Office** #1310, Seoul Forest IT Valley, 77, Sungsuil-ro, Sungdonggu, Seoul, Korea, 04790 **T.** 82.2.6213.6210 **F.** 82.2.6213.6216 **E.** info@acichemical.com

**Factory 1** 65, Mokrae-ro, Danwon-gu, Ansan-si, Gyeonggi-do, Korea, 15605 **T.** 82.31.499.8808 **F.** 82.31.499.3308

**Factory 2** Address No 609, 610, Takra #5, 555, Byeolmangro, Danwongu, Ahnsan City, Kyounggi Province, Korea, 15434 **T.** 82.31.499.8808 **F.** 82.31.499.3308

**Jeju Office** 225-66, Songji-gil, Jeju-si, Jeju-do, Korea, 63330 **T.** 82.64.724.3400 **F.** 82.64.724.3401



**Avermann**

Avermann Maschinenfabrik GmbH & Co. KG Lengericher Landstraße 35 49078 Osnabrück . Deutschland

**T.** +49.5405.505 - 0 **F.** +49.5405.6441 **E.** info@avermann.de